

## Gigabit Ethernet Converters 1000BaseT to 1000BaseSX/LX



### Media Wizard Modules

- 1000BaseT to 1000BaseSX/LX converter modules
- Complies with 802.3ab and 802.3z
- Auto-Negotiation on copper and fiber ports (HDX/FDX)
- Flow control (Pause) support on copper and fiber ports
- Extended UTP cabling support
- Automatic MDI/MDIX crossover and polarity correction
- Multimode: up to 220/550m and special version for up to 2Km
- Singlemode: up to 70Km, Single Fiber up to 20Km and CWDM up to 70Km
- Single Fiber options up to 20Km
- Enhanced LED indications
- Manageable
- Plug & play, hot swappable, slot independent module

The WIZ-601/602 are Gigabit Ethernet fiber optic converters offering bi-directional conversion between Gigabit fiber and Gigabit copper networks in compliance with IEEE 802.3 standards. The modules extend the span of your Gigabit network to up-to 70 Km.

- WIZ-601 - single port converter module
- WIZ-602 - dual port converter module

The WIZ-601/602 support auto-negotiation for the duplex and flow control operation modes. The copper port(s) supports auto MDI crossover and polarity correction, as well as superior performance of up-to 180m full duplex Gigabit operation over standard CAT 5 cables. The fiber port(s) are available with a choice of 850nm (SX) interface supporting distances of 220/550m over 50/62.5 micron MM fibers respectively, or (LX) 1310nm/1550nm interfaces supporting distances up-to 70Km over SM fibers. The F/O interfaces are available with SC or LC connectors. The modules are also available in a special M2 model that support up to 2Km over MM fiber.

The WIZ-601/602 are available in Single Fiber (SF) and CWDM versions, supporting distances up to 20Km and 70Km respectively over SM fiber. The SF versions use dual wavelength WDM technology that assures better isolation and link performance. A SF link is sold in pairs, type-A (TX-1550nm, RX-1310nm) on one end and type-B (TX-1310nm, RX-1550nm) on the other end.

The WIZ-601/602 Gigabit physical layer (PHY) converters consist on advanced DSP technology that provides highly reliable robust solution for any Gigabit link.

Color LED indicators provide easy monitoring of the operation and status of each port.

To maximize efficiency and minimize installation costs, the WIZ-601/602 can be installed in the Media Wizard's 16, 4, 2 or single slot modular chassis, saving rack space and main outlets as well as providing flexibility and easy service and maintenance. The chassis support optional redundant power supply and central SNMP management. All chassis are available with wide range AC or DC power supplies.



MEDIA WIZARD

A 3M Company

**Quante**  
Netzwerke GmbH

# Typical Configuration

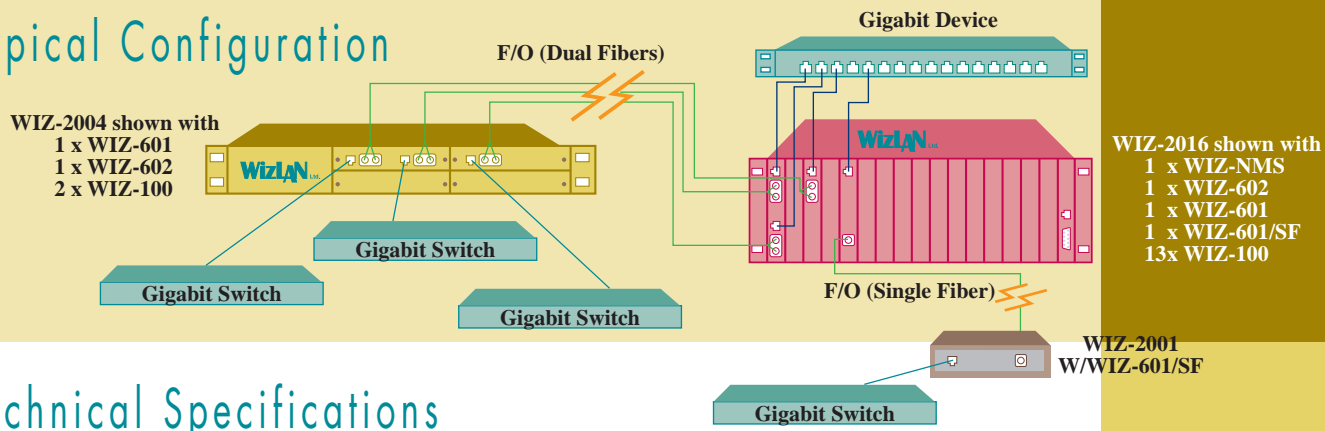

## Technical Specifications

WIZ-601/602 - Gigabit Ethernet 1000BaseT to 1000BaseSX/LX Converter Modules

### 1000BaseT Port(s)

4 pairs RJ-45 connector(s)
Auto-negotiation (Duplex, Flow control)
Auto MDI crossover and polarity correction
Up-to 180 meter (590 ft) over CAT 5 cable

### LED Indicators (per port)

1000BaseT RJ-45 Port(s)	Link - copper link established
	TX - data transmitted by the port
	RX - data received by the port
1000BaseSX/LX F/O Port(s)	FDX - the port operated in FDX mode
	Link - F/O link established

### Special Features

Auto MDI crossover
Auto polarity correction
Next page capabilities

### Standard Compliance

IEEE 802.3ab - 1000BaseT
IEEE 802.3z - 1000BaseSX/LX
Pause capabilities flow control

### Technology

Physical Layer Converter
--------------------------

### 1000BaseSX/LX port(s)

• Interface			
Multimode	850nm	SC, LC	
Singlemode	1310nm	SC, LC	
	1550nm	SC, LC	
• Distance/Power Budget			
Multimode	62.5/50µ	220/550m	8dB or 2Km
Singlemode	9/125µ	10km	20km 50km 70km
		10dB	17dB 17dB 24dB
• Single Fiber (dual wavelength) Distance/Power Budget			
Singlemode	9/125µ	10Km	20Km
min power budget:		12dB	17dB

### Power Consumption (Installed in Media Wizard chassis)

DC Power Consumption (PU)	WIZ-601 - 1.4 PU
(Power Units per module)	WIZ-602 - 2.5 PU

### Safety & Emission

CE, FCC Part 15, EN60950
--------------------------

### Environment

	°C	°F
Operating Temperature	0 to 45	32 to 113
Storage Temperature	-40 to 85	-40 to 185
Humidity	10% to 90% non-condensing	

### Dimensions (Module)

Height	Width	Depth
130mm (5.1")	25.4mm (1")	140mm (5.5")

### Ordering Information (Dual Fiber) For CWDM versions and/or other connectors/distances please contact WizLAN representative.

WIZ-601M/[x]	1000BaseT to 1000BaseSX (MM, 850nm VCSEL, 8dB, 0-220/550m, [x]) Converter, inc. status mgmt.
WIZ-601M2/[x]	1000BaseT to 1000BaseSX (MM, 1310nm 0-2Km, [x]) Converter, inc. status mgmt.
WIZ-601/[Sn]/[x]	1000BaseT to 1000BaseLX (SM, [Sn]/[x]) Converter, inc. status mgmt.
WIZ-602M/[x]	Dual port 1000BaseT to 1000BaseSX (MM, 850nm VCSEL, 8dB, 0-220/550m,[x]) Converter, inc. status mgmt.
WIZ-602M2/[x]	Dual port 1000BaseT to 1000BaseSX (MM, 1310nm, 0-2Km,[x]) Converter, inc. status mgmt.
WIZ-602/[Sn]/[x]	Dual port 1000BaseT to 1000BaseLX (SM, [Sn]/[x]) Converter, inc. status mgmt.

M/M2	[x]=Type of F/O connector: SC, LC
[Sn]=S	Singlemode 1310nm, 10dB, 0-10Km [x]=Type of F/O connector: SC, LC
[Sn]=S1	Singlemode 1310nm, 17dB, 0-20Km [x]=Type of F/O connector: SC, LC
[Sn]=S2	Singlemode 1550nm, 17dB, 10-50Km [x]=Type of F/O connector: SC, LC
[Sn]=S3	Singlemode 1550nm, 24dB, 30-70Km [x]=Type of F/O connector: SC, LC

### Ordering Information (Single SM Fiber Type A/B)

WIZ-601/602/SF-A/B/[Sn]/SC	1000BaseT to 1000BaseLX (SM, Single Fiber - A/B, [Sn]/[x]) Converter, inc. status mgmt.
/SF-A = type-A (TX-1550nm, RX-1310nm)	
/SF-B = type-B (TX-1310nm, RX-1550nm)	
[Sn]=S	1550/1310nm 12dB 0-10 Km
[Sn]=S1	1550/1310nm 17dB 0-20 Km

All specifications are subject to change without notice. Neither manufacturer nor seller shall be liable for any loss, damage, or injury, direct or consequential, arising from the inability to use the product.

**Quante Netzwerke GmbH**  
**Ahrensburger Straße 8**  
**D-30659 Hannover**

[www.quante-netzwerke.de](http://www.quante-netzwerke.de)

**Tel: +49 (0)511 / 74 01 92 - 0**  
**Fax: +49 (0)511 / 74 01 92 - 100**

Rev.02