

IP Invers-MUX Loop-IP6440

IP - 4 x E1



Features

- Support WAN link, which is virtually concatenated n x E1 (n can be 1 to 4)
- Support up to 64ms (configurable for 16, 32, and 64ms) of transmission different delay between E1s.
- GFP (Generic Frame Protocol) is used to map the Ethernet packet into the virtually-concatenated E1's.
- Support 10/ 100 BaseT Ethernet
- Support Tx (Transmit)/ Rx (Receiver) auto reverse function
- Support 10M or 100M auto detecting function
- Support timing sources selection from (1) a certain E1 from n x E1, (2) External clock, (3) Internal
- Support Alarm Relay
- Support local control and diagnostic via DB9S console port
- Support Ethernet, SNMP, and inband management
- Support management firewall for blocking all malicious management packages.
- Support VLAN packet transparent:
 - Up to 1916 bytes for optional MAC learning is included.
- Multicolor LED indicators.

Description

The Loop-IP6440 IP Inverse Mux provides connectivity from 10/100 BaseT LAN to E1 WAN through multiple E1, up to 4 E1 links. Loop-IP6440 also provides a bridging function from Ethernet to E1 links. This unit can provide customers from 2Mbps to 8Mbps network bandwidth.

Loop-IP6440 offers automatic E1 channel failure detection and can re-assign the number of E1 channels for transport of Ethernet traffic. For example, if there are 4 E1s configured for 10/100 Ethernet traffic transport, and one E1 fails during the service, the other 3 pick up the entire load. This minimizes loss of IP packets.

Loop-IP6440 support DB9S console port, which allows users to execute in-service diagnostics and fault isolation from a local or remote terminal. Loop-IP6440 also allows remote site to telnet via Ethernet port. The IP6440 series also provides multicolor LED indicators on the front panel and ACO (Alarm Cut-Off) button.

Loop-IP6440 IP I-MUX Product Specification

Line Interface

Line Rate	2.048 Mbps \pm 50 ppm	Connector	BNC (75 ohm), RJ48C (120 ohm)
Data Rate	n x 30 x 64Kbps (n=1 to 4) or n x 29 x 64Kbps (n=1 to 4)	Output signal	ITU G.703
Line Code	AMI/ HDB3	Electric	75 ohm/ 120 ohm twisted pair
Input Signal	ITU G.703	Jitter	ITU G.823

Clock Source

Primary Clock	Any one of E1 line, external(option), internal
Secondary Clock	Any another of E1 line, external(option), internal

Diagnostics Test

Loopbacks	Line Loopback and Payload Loopback
Remote Loopbackfs	Line Loopback, and Payload Loopback

Performance Monitor

Performance Store	Last 24 hours performance in 15-minute intervals and last 7 days in 24-hour summary line, and user
Performance Reports	Date & Time, Errored Second, Unavailable Second, Bursty Errored Second, Severe Errored Second, Controlled Slip Second, and Loss of Frame Count
Monitor Registers	Line and User
Alarm History	Alarm Type (i.e. Master Clock Loss, RAI, AIS, LOS, BPV, ES)
Alarm Queue	Maximum 40 alarm records which record the latest alarm type, location, and date & time
Alarm Threshold	BPV, ES, UAS

Ethernet

Connector	RJ45
Protocol	Telnet and embedded SNMP
Speed	10 or 100 BaseT, auto-detect

Physical

Dimensions	432 x 44 x 255 cm (WxHxD)
Power Source (AC)	100-240V, 50/60 Hz AC
Power Source (DC)	48Vdc: 42-72 Vdc, dual DC hot swappable
Power Consumption	< 30 watts
Temperature	0 -50 °C
Humidity	0-95% RH (NON-CONDENSING)
Mounting	Desk-top stackable, wall mount

Application Illustration



Loop-IP6440 IP I-MUX Panel Views

Front Panel

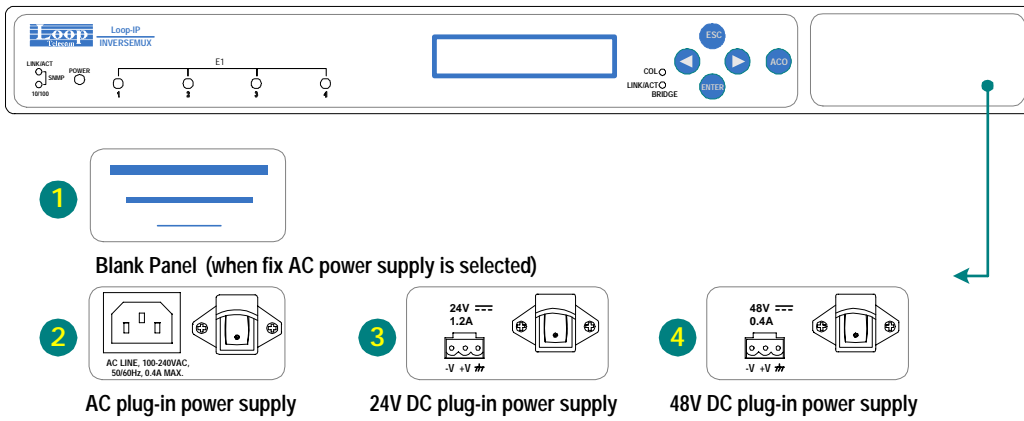

Rear Panel

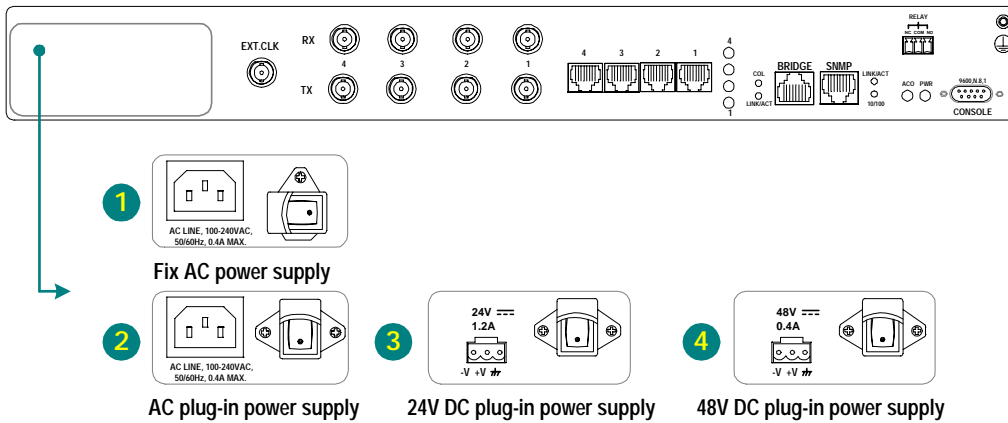

Vertriebs - und Servicepartner für
Deutschland
Niederlande und Österreich

Quante Netzwerke GmbH
Ahrensburger Str. 8
D-30659 Hannover

www.quante-netzwerke.de

Tel: +49 (0)511 / 74 01 92 - 0
Fax: +49 (0)511 / 74 01 92 - 100